

BROCHURE

RayWhite[®]



▷ D4, D5 & D6,

28A Gwynne Street, Firlie SA 5075



Chris Xu
Sales Executive
0433 770 616
chris.xu@raywhite.com



Marco Lai
Sales Associate
0433 733 368
marco.lai@raywhite.com

W LOCATION

RayWhite

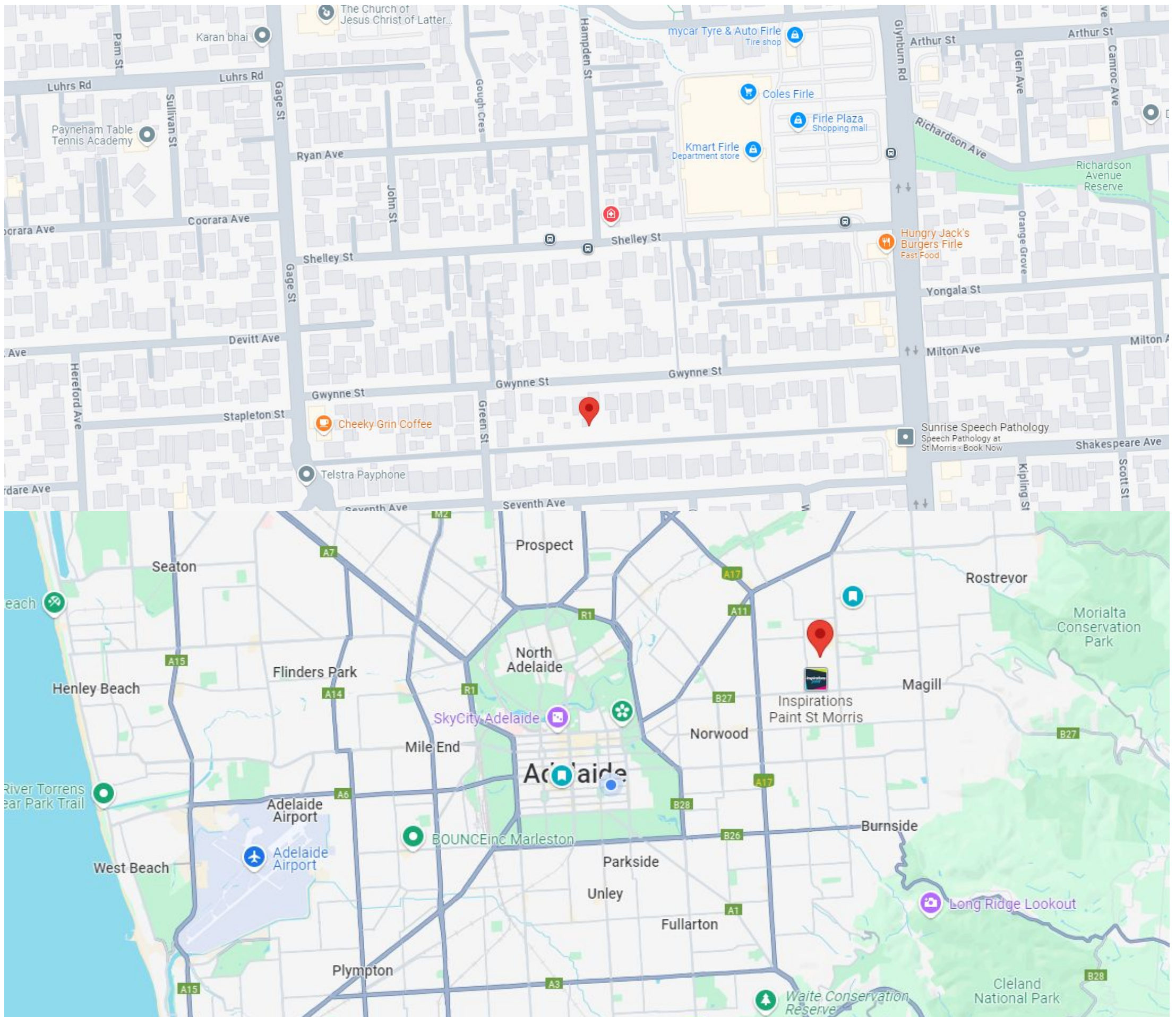

Adelaide CBD – 7.2km

Service SA – 1.2km

Glynburn Plaza – 1.2km

The Parade – 1.6km

Norwood International High School - 2.9km

Firle Plaza – 750m

Daly Oval – 2km

UniSA Magill Campus – 2.3km

Trinity Gardens School – 1.3km

Note: This plan is for illustration purposes only. All dimensions are approximate. While every endeavor has been made to verify the correct detail neither the vendor, the agent, nor the designer accepts liability for error or omission.

W LOCATION



Discover the essence of suburban living in Firle, a peaceful and well-located neighbourhood in Adelaide's popular Eastern suburbs. With Firle Plaza and Glynburn Road shopping nearby, all your everyday needs are within easy reach. Take a relaxing stroll to the nearby reserves and immerse yourself in the tranquillity of the green, leafy environment. Firle boasts a variety of shopping and dining options, ample green parks, and excellent educational facilities, making it a well-rounded and attractive suburban retreat.



LIVING, KITCHEN & DINING AREA

RayWhite[®]



This stunning multi-level home features an eye-catching, contemporary facade. Its grand design and multiple levels offer a variety of living spaces, perfect for hosting gatherings or unwinding in comfort.

The heart of these homes is undoubtedly the modern kitchen, beautifully enhanced with premium stone benchtops, creating a true culinary paradise.

BATHROOM



The bathroom, fully tiled and bathed in natural light, provides a calming atmosphere perfect for starting and ending your day.

SITE PLAN

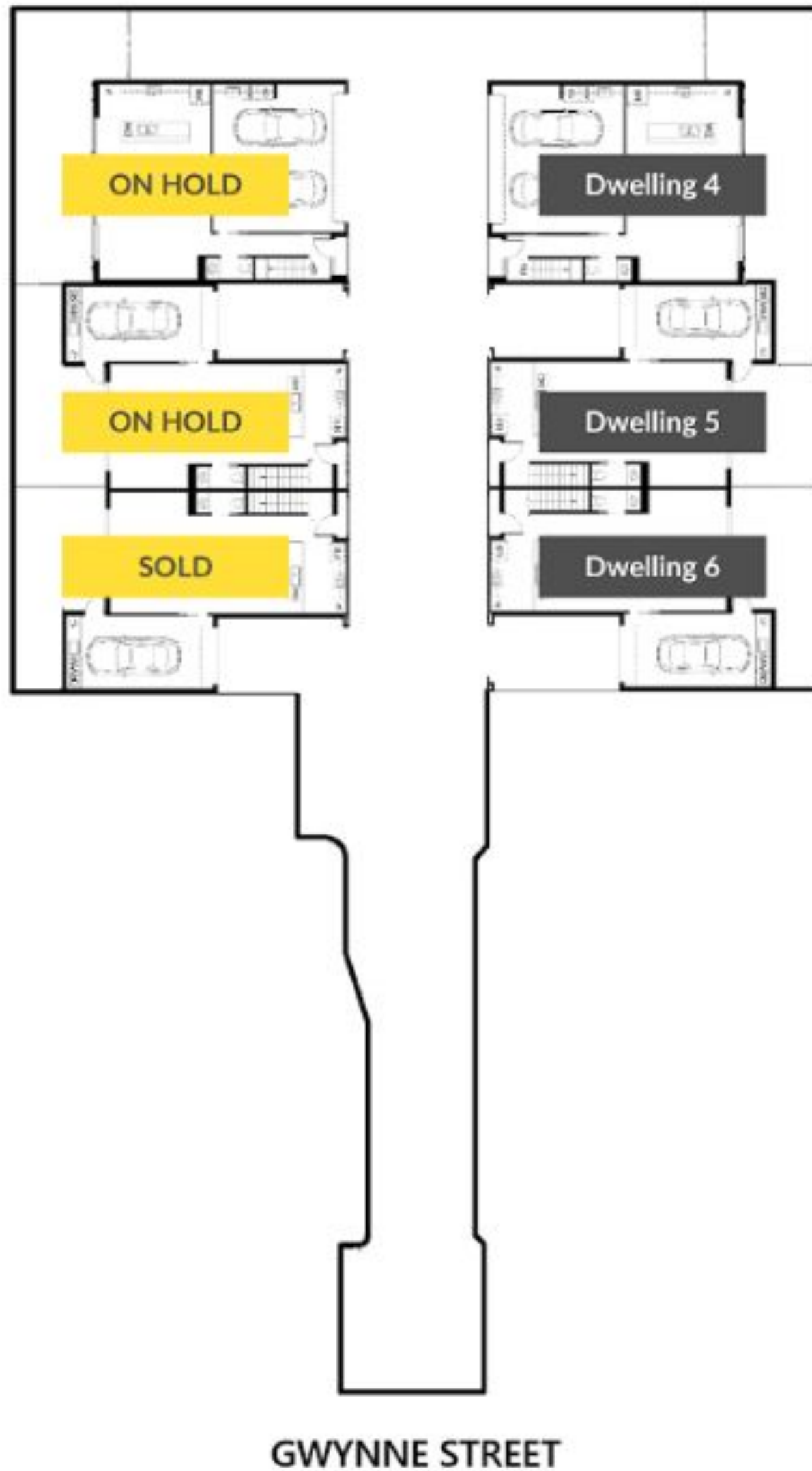

WFLOOR PLAN

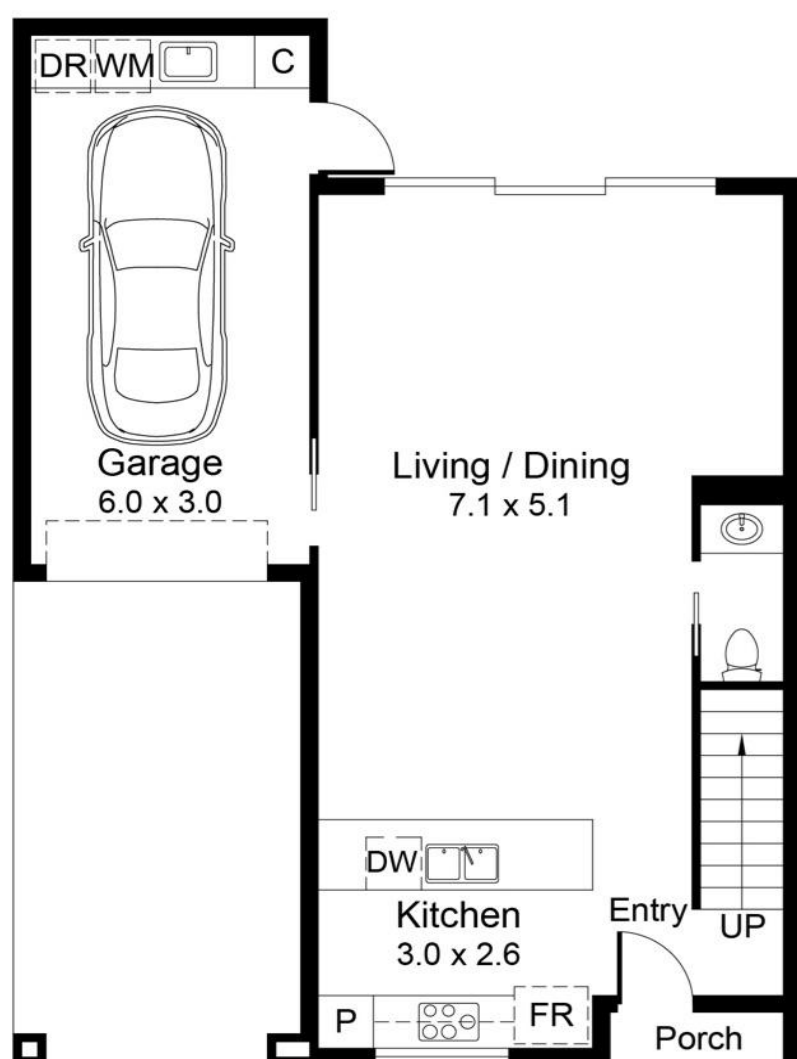

Ground Level

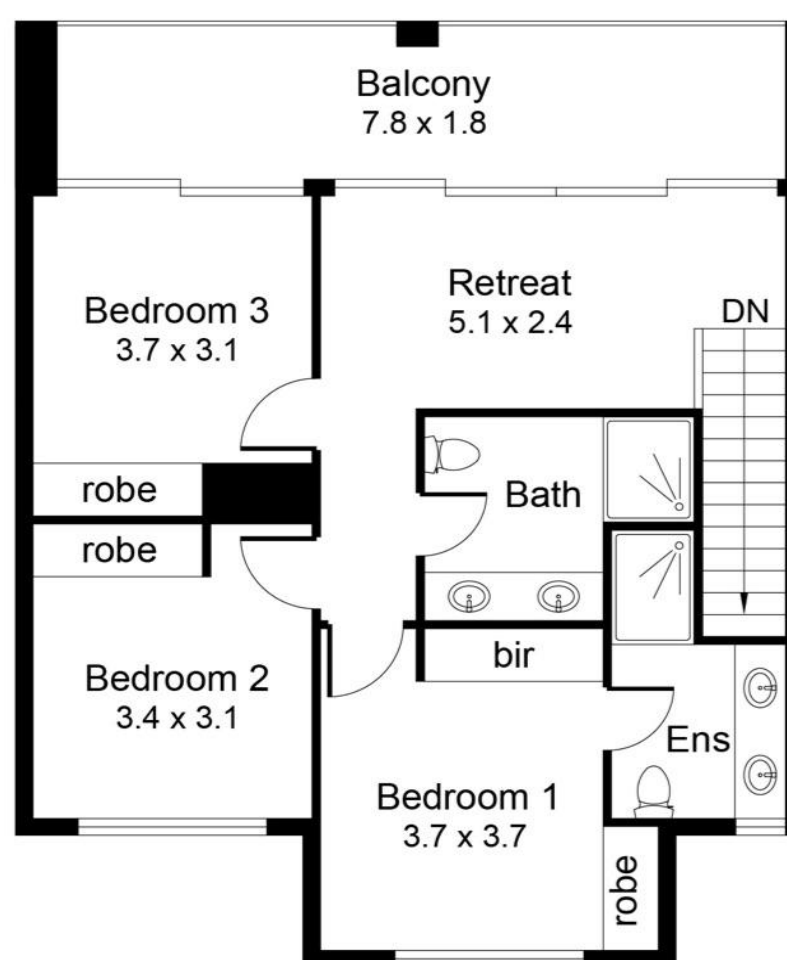

Upper Level

Dwellings 5 & 6

160m²	53m²	70m²	21m²	16m²
TOTAL	Ground Living	Upper Living	Garage	Balcony

Whilst every attempt has been made to ensure the accuracy of the floor plan contained here, measurements of doors, windows, rooms and any other items are approximate and no responsibility is taken for any error, omission, or misstatement. This plan is for illustrative purposes only and should be used as such by any prospective purchaser.



Note: This plan is for illustration purposes only. All dimensions are approximate. While every endeavor has been made to verify the correct detail neither the vendor, the agent, nor the designer accepts liability for error or omission.

WFLOOR PLAN

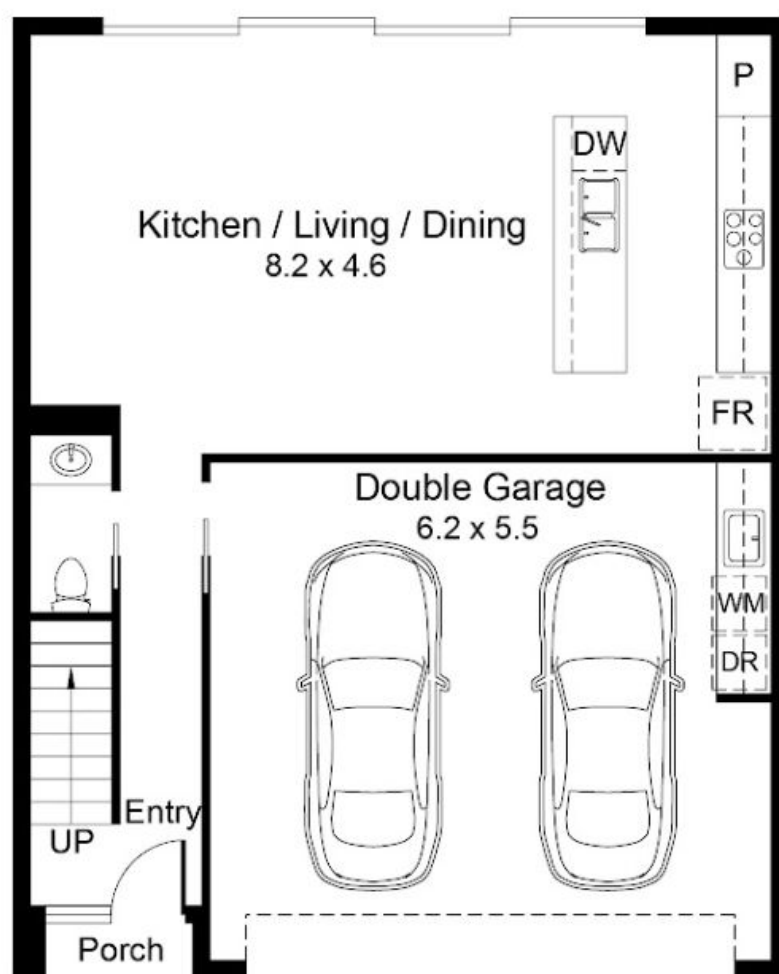

Ground Level



Upper Level

Dwelling 4

179m²	53m²	82m²	36m²	8m²
TOTAL	Ground Living	Upper Living	Garage	Balcony

Whilst every attempt has been made to ensure the accuracy of the floor plan contained here, measurements of doors, windows, rooms and any other items are approximate and no responsibility is taken for any error, omission, or misstatement. This plan is for illustrative purposes only and should be used as such by any prospective purchaser.



INTERNAL FINISHES



PROJECT: 008-024
28-30 GWYNNE STREET
FIRLE SA

ITEM: SINK MIXER
Pantry Sink Mixer
Greens Galiano Pull- Down Sink Mixer

LOCATION: Kitchen

QUANTITY: 1 Per Dwelling

SUPPLIER: Aglae

FINISH: Dwelling 1, 3 & 5 – Brushed Brass
Dwelling 2, 4 & 6 – Brushed Copper

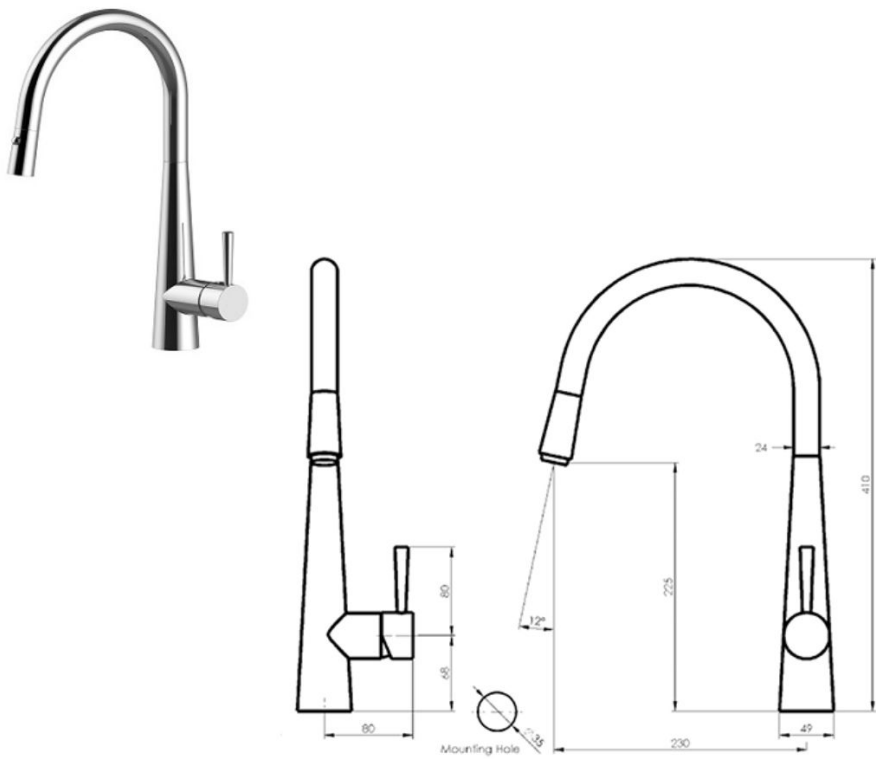

PROJECT: 008-024
28-30 GWYNNE STREET
FIRLE SA

ITEM: UNDERMOUNT SINK
Castano Orta 750 Square Undermount Sink

LOCATION: Kitchen

QUANTITY: 1 Per Dwelling

SUPPLIER: Aglae

FINISH: Stainless Steel

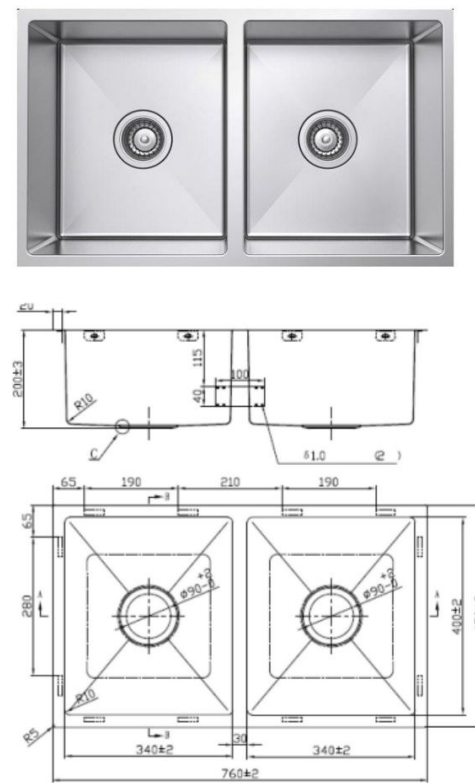

ITEM: WASTE BIN
2 x 40L Bucket, Door Pull
418w x 615h x 518dmm
(Suits Cabinet width: 450mm)
KC240SCD-W

LOCATION: Kitchen x 1

QUANTITY: 1 Per Dwelling

SUPPLIER: Hideaway

FINISH: White



ITEM: GAS COOKTOP
Smeg 72cm Classic cooktop – left wok
725W x 510D x 40H mm
Code: PX375LAU

LOCATION: Kitchen

QUANTITY: 1 Per Dwelling

SUPPLIER: Spartan Electrical

FINISH: Stainless Steel

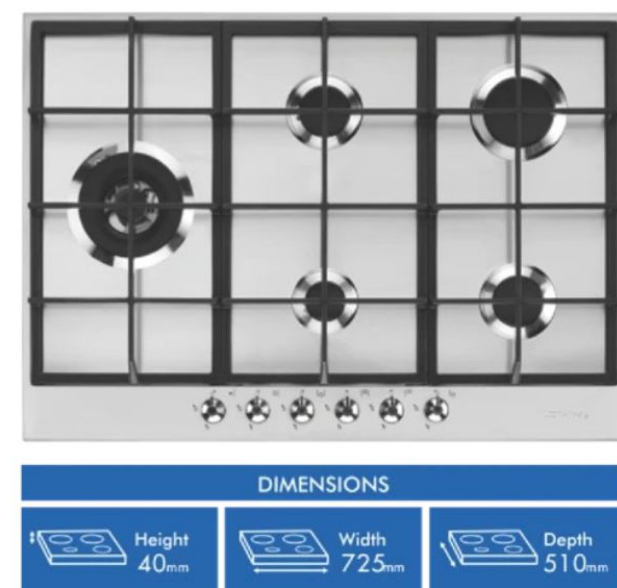

Note: This plan is for illustration purposes only. All dimensions are approximate. While every endeavor has been made to verify the correct detail neither the vendor, the agent, nor the designer accepts liability for error or omission.

INTERNAL FINISHES

ITEM: BUILT IN OVEN
Smeg 60cm Classic Pyrolytic Oven Matt Black
Code: SOPA6301TN

LOCATION: Kitchen

QUANTITY: 1 Per Dwelling

SUPPLIER: Spartan Electrical

FINISH: Matt Black



ITEM: INTEGRATED DISHWASHER
Smeg 60cm Fully Integrated Dishwasher
Code: DWAFI6314-2

LOCATION: Kitchen

QUANTITY: 1 Per Dwelling

SUPPLIER: Spartan Electrical

FINISH: Refer to drawings and finishes schedule for panel finish

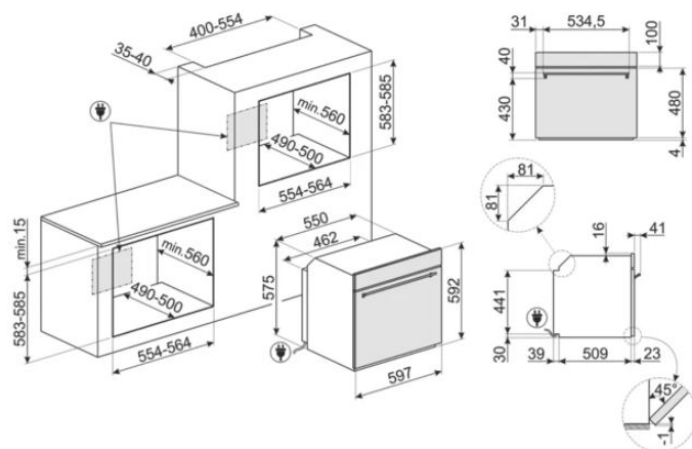

DIMENSIONS

Height 818mm

Width 598mm

Depth 570mm

LOCATION: Kitchen Island

QUANTITY: 3 Per Dwelling

SUPPLIER: About Space Lighting

FINISH: Gold – Dwelling 2, 4, & 6
Black – Dwelling 1, 3 & 5



INTERNAL FINISHES

ITEM: TOP MOUNTED BASIN
Timberline Allure White

LOCATION: Ensuite x 2 - (Dwelling 1-6)
Bathroom x 2 - (Dwelling 1, 2, 5 & 6)
Bathroom x 1 - (Dwelling 3 & 4)

QUANTITY: 4 Per Dwelling 1, 2, 5 & 6
3 Per Dwelling 3 & 4

SUPPLIER: Aglae

FINISH: Matt White



ITEM: ABOVE COUNTER BASIN
Timberline Allure Flute Collection

LOCATION: Ground Floor WC - (Dwelling 1-6)

QUANTITY: 1 Per Dwelling

SUPPLIER: Aglae

FINISH: Matt White

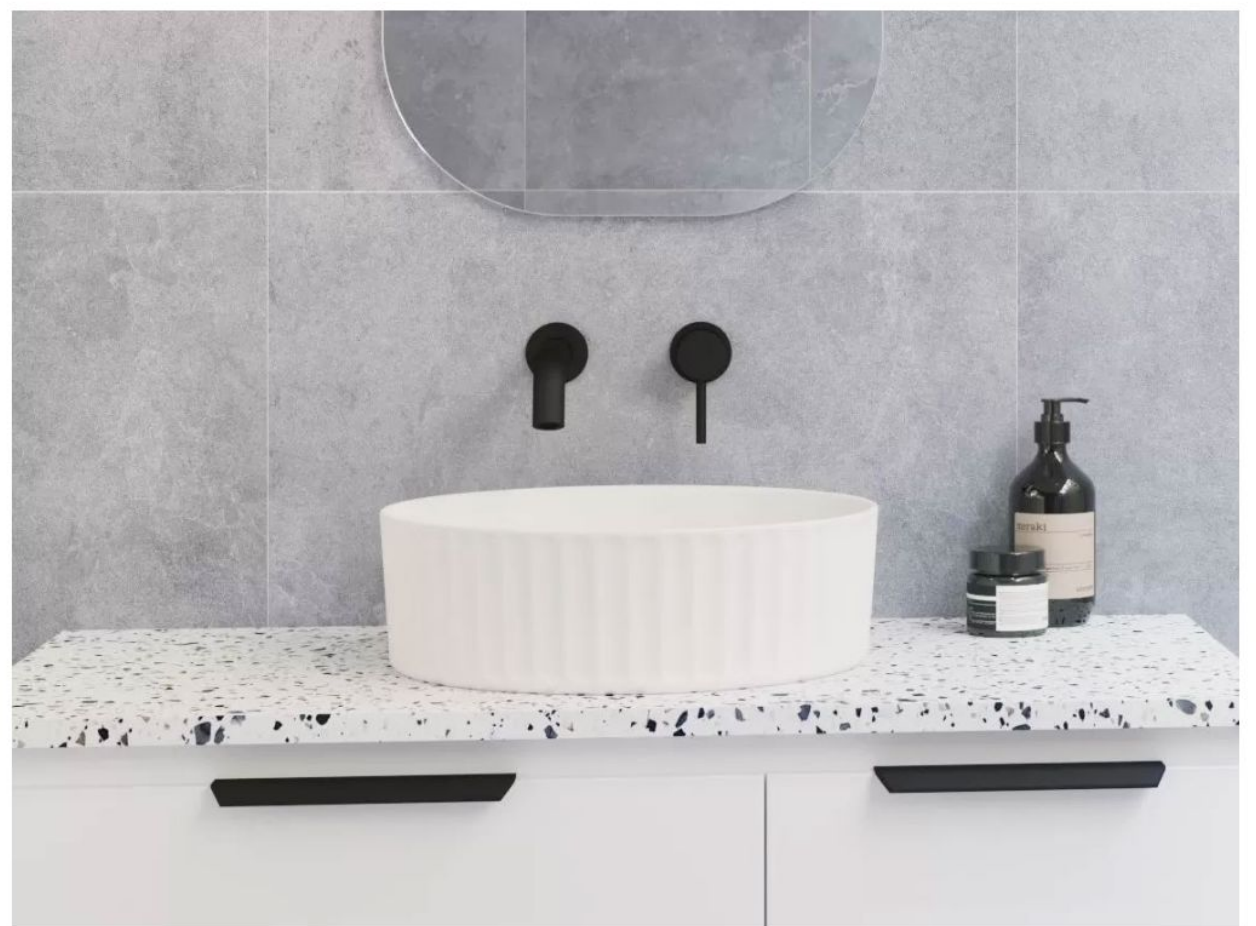

ITEM: OVERHEAD SHOWER
Meir Round Wall Shower
200mm Rose, 400mm Curved Arm
Code: MA0904-400-CH

LOCATION: Ensuite x 1

QUANTITY: 1 Per Dwelling

SUPPLIER: Aglae

FINISH: Dwelling 1, 3 & 5 – Tiger Bronze
Dwelling 2, 4 & 6 – Champagne

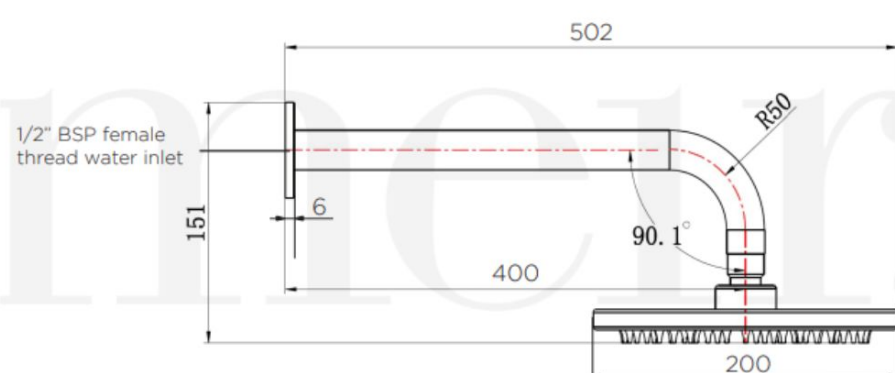

ITEM: TOWEL RAIL
Meir 600mm Round Single Towel Rail

LOCATION: Bathroom

QUANTITY: 2 Per Dwelling

SUPPLIER: Aglae

FINISH: Dwelling 1, 3 & 5 – Tiger Bronze
Dwelling 2, 4 & 6 – Champagne

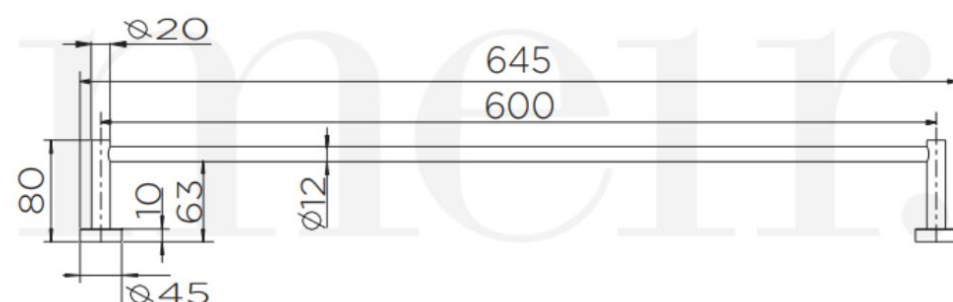

Note: This plan is for illustration purposes only. All dimensions are approximate. While every endeavor has been made to verify the correct detail neither the vendor, the agent, nor the designer accepts liability for error or omission.

INTERNAL FINISHES

ITEM: FREESTANDING BATH
Caroma Luna 1400L Back to Wall Bath

LOCATION: Bathroom

QUANTITY: 1 Per Dwelling 3 & 4

SUPPLIER: Aglae

FINISH: White

ITEM: WALL LIGHT
Forte 12V LED wall light 120mm Yosh Shade

LOCATION: Bathroom x 2
Ensuite x 2

QUANTITY: 4 Per Dwelling

SUPPLIER: About Space Lighting

FINISH: Glass – Opal
Body - Black

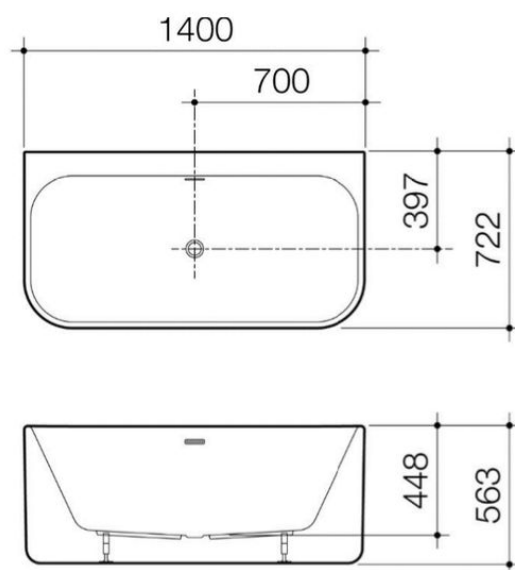

ITEM: PENDANT LIGHT
Toledo Opal Glass Pendants
Dimensions: Diam: 200mm

LOCATION: Study Nook

QUANTITY: 1 Per Dwelling 3 & 4

SUPPLIER: About Space Lighting

FINISH: Brass and Grey

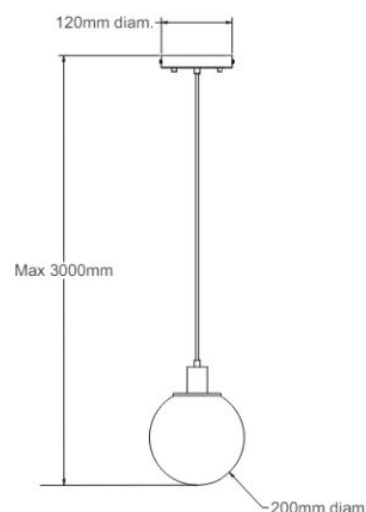

ABOUT US

RayWhite



Ray White Adelaide City brings you unparalleled technology, dedication & and a real passion for customer service. You can be sure whether you sell, buy, or rent with us - you're getting local real estate experts.

Led by Adelaide's number one agent, Andrew Downing, Ray White Adelaide City opened its doors in early 2021 with a vision to provide Adelaide with a fresh, modern & genuine approach to real estate. Our quality service & and extensive knowledge of the market have seen us quickly become the go-to agency for all real estate matters in Adelaide. With a combined 60+ years of experience selling, buying & and leasing property in Adelaide CBD & and surrounding suburbs, the Ray White Adelaide City team's knowledge & and passion for property are second to none. Our professionalism & and integrity ensure we always endeavor to achieve the best possible result for our clients & and friends.

We pride ourselves on offering an unparalleled experience whether you are looking to buy, sell, or rent. We understand how important this process is, from first home buyer to investor, landlord to tenant, we are with you every step of the way to ensure your experience is stress-free & and enjoyable.

Note: This plan is for illustration purposes only. All dimensions are approximate. While every endeavor has been made to verify the correct detail neither the vendor, the agent, nor the designer accepts liability for error or omission.